

# The “Open Altra Economia” (OAE) project: Open Data and Open Source Software for a sustainable economics

Stefano Puglia\*, Francesco Ficarola, Alessandro Leoni (*WLAB Srl, Rome, Italy*)

Davide Lamanna (*Binario Etico, Rome, Italy*)

Simone Leoni (*Rome, Italy*)

## **Abstract**

“Open Altra Economia” (OAE) is an Italian R&D project experimenting with Open Data and Open Source Software (OSS) to advance the cause of "Altra Economia Lazio" (AEL), a consortium of social and economic structures whose main principles are based on equity, solidarity, efficiency and sustainability. These concepts are also at the core of degrowth and “downshifting” movements created to build a good society, allow the planet to sustain itself and improve human well-being and social equity. According to national rules promoting and regulating social and economic innovation and key EU policies stating that technological progress should address grand and societal challenges, we are working to: 1) make available on the Semantic Web of Data linked open datasets about AEL's business activities and not-for-profit organisations that will be free to use, reuse and redistribute; 2) study and devise free OSS platforms, tools and end-user applications to collect, maintain, "crowd-source" and provide such data in a creative, innovative and original fashion.

## **Introduction**

The socio-economic model underlying the major capitalist market economies has been in dire straits for a number of years. We are now better aware that in a fragile market system only based on GDP growth, severe global crises can erupt at any time due to largely uncontrolled reasons (e.g. excessive creation of financial debt in the hope of wealth creation). Allegedly, emerging degrowth and “downshifting” movements promise to represent a creative way out of these crises to build a good society, allow the planet to sustain itself and improve human well-being and social equity.

In a gradual approach to foster novel economic policies and promote sustainable technological and social alternatives at the forefront of many degrowth practices, forms of so called "participatory economics" [1] and ecological economics [2] seem to be reaching their maturity in various parts of the world. Indeed, these emerging economic structures might represent one of the main forceful drivers in the transition towards a successful and long lasting sustainability.

In the Italian Lazio region, where the Italian capital Rome is located, "Altra Economia Lazio" (AEL) is a consortium of economic structures whose main principles are based on equity, solidarity, efficiency and sustainability. These structures, that include but are not restricted to fair trade shops, organic locally grown food producers, community-supported agricultures, community-based ecological and social enterprises engaged in delivering local services (e.g. food, transport, energy, community education, maintenance and repair, recreation and sport, free knowledge, culture), have been promoted and regulated since 2008 by an inspired example of forward-looking local legislation [3]. According to a Regional Council Act, all activities pertaining to AEL should be sustained, assisted and improved and their goods and services properly advertised to the population at large also with specific events emphasising what we may call a more critical and ethical consumption.

Key considerations for future EU policy [5,6,7,8,9,10] state that technological innovation should address grand and societal challenges which lie ahead in time. To us, this means that novel technologies progressively penetrating the whole of our society should drive and support social innovation and individual behaviour change besides providing (improved) solutions to technical

---

\* Corresponding author, Email: stefano.puglia@w-lab.it

issues and problems. For the past few months we have been working on "Open Altra Economia" (OAE), a small project aiming at releasing and experimenting with Open Data [11] and Open Source Software (OSS) [12] to advance the cause of AEL.

In particular, we are making available open datasets about AEL's commercial businesses and not for profit organizations (NPOs) that will be free to use, reuse and redistribute as required by Italian regulations and advocated by EU framework programmes and policies [4,17,18,5]. Furthermore, we are studying and devising free OSS platforms, tools and mobile apps to collect, maintain, "crowd-source" and provide such data in a creative, innovative and original fashion.

Our main contributions in the paper can be summarised as follows:

- a discussion on the general context of AEL as an example of social and economic innovation to face the current crisis by building and regulating strong alliances of businesses having fairness, sustainability and human interaction at the heart of their "value proposition";
- the design and ongoing implementation of business processes, novel open data management and knowledge systems to host information and infer knowledge on AEL in the emerging Semantic Web of Data;
- a brief report on the current implementation of envisaged free software applications as a first example of use, reuse and redistribution of open data to reach out to people and raise awareness for further knowledge generation and sharing for the benefit of AEL.

## **When AEL meets Open Data and Open Source Software**

In the Italian Lazio region a 2008 Regional Council Act states that AEL is a consortium of activities including, among the others, organic agriculture, production of eco-friendly goods and services, fair trade shops, critical consumption and ethical shopping, ethical finance and banking, energy conservation actions, renewable and green technologies, reuse, recycling and redistribution of consumer goods, non monetary systems of exchange, free software, sustainable tourism and travelling. In promoting, sustaining and sponsoring all these activities, the act represents, in our opinion, an important attempt to admit and legally certify the existence of new forms of emerging sustainable economic and social practices.

In other words, AEL's innovative value proposition to support that long lasting sustainability advocated by degrowth thinkers and activists has been legally and politically acknowledged in the Italian capital's geographical region for a number of years.

As information technologists fully concerned with the wide impacts that technological innovation should have on society and its most promising transitions in the present and future times (e.g. [5]), we consider it worthwhile to try and support the AEL consortium through information and communication technologies capable of advancing its cause in the Rome area and its surroundings.

Open Data include novel approaches and technologies based on the idea that "certain data should be freely available to everyone to use and republish as they wish, without restrictions from copyright, patents or other mechanisms of control" [11]. Together with other similar "Open" movements such as those supporting and promoting Open Source Software (OSS) [12] to make computer programs available to the general public for use and/or modification from its original design, Open Data has recently gained popularity with the rise and launch of Open Government [13] initiatives. Many legislations worldwide are now bound to disclose information of public interest to increase both transparency and democratic participation therefore helping produce greater knowledge and societal progress [13].

Based on this assumption and triggered by Italian local and national legislation on Open Data and Government (e.g. [4,17,18]), we have been working for some time on a 1-year national funded

R&D project called "Open Altra Economia" (OAE) where we are experimenting with Open Data and OSS in the very context of AEL. We expect to achieve a number of benefits through the OAE project.

First, taking census of "fresh" and up-to-date data on AEL and making the effort to represent this data in a common, open, standard format available to anyone in the Semantic Web of Data [14] is inherently meaningful, relevant and innovative given the absence of such data at the time of this writing.

Secondly, by publishing open dataset on AEL we hope to help both AEL's stakeholders and local regulators/administrators better assess and appraise the AEL consortium itself in Rome and the whole Lazio region. Being potentially able to query AEL's semantically enriched open data might help reveal non-obvious hidden interpretations and phenomena of interest on people's behaviours, consumption patterns and general AEL's inner relationships and dynamics. This might help tighten existing connections among AEL's businesses and/or create new ones to strengthen the consortium and further the movement's campaigns and causes.

Finally, a free publication of applications and their progressive release to the general public as OSS may help achieve a citizens' participation and cooperation which is one the fundamental principles in an open democratic society. We plan to "keep people in the loop" by having ordinary citizens interested in the AEL consortium increasingly play a significant role in that arena. We are developing applications to let people give feedback, control and "crowd-source" information to progressively increase data volume and improve data quality on AEL. Moreover, giving access to the source code that will be released might hopefully inspire more developers and technologists to code additional software to foster knowledge generation and sharing on AEL-related matters and back the consortium to garner extra promotion of the movement's cause, ideas and objectives.

## OAE's Linked Open Data

OAE project's first technical contribution has been the collection, management and publication of Linked Open Data (LOD) [15,16] on AEL. To this end, we have been inspired by existing approaches and methodologies [19,20].

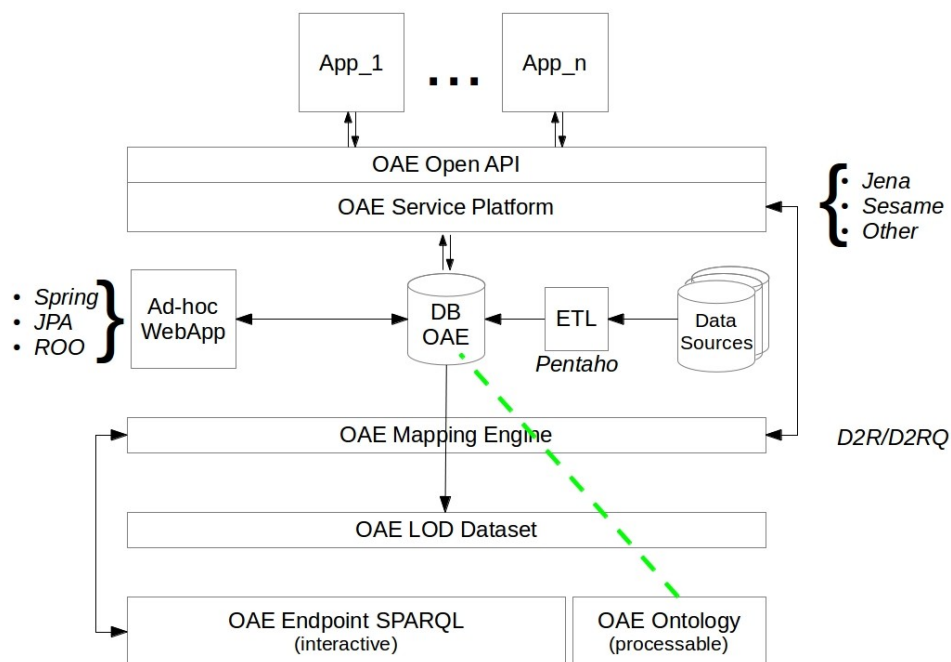

Figure 1: OAE – Overall view of system architecture

Initially, we have identified data sources about AEL's activities, businesses and NPOs. Then, given the utterly heterogeneous nature of this data which was partly structured and partly unstructured, we have had to proceed to a “data reconciliation” step by conceiving and designing an ad-hoc conceptual and logical data model that was eventually implemented as a “unified” persistence.

In a later step, we have carried out an automatic data transfer from native data sources to the unified persistence by designing, fine tuning and running extract, transform and load (ETL) specific procedures in an ad-hoc OSS [21] tool. We have also designed and implemented a Web application to be able to manually operate on data automatically loaded into the unified persistence which may often lack quality and accuracy.

Finally, we have identified, installed, configured and properly programmed whenever necessary a number of OSS tools to maintain the unified and reconciled data and deliver it as LOD triples ready to be used by applications and/or properly stored in triplestores.

Figure 1 shows an overall view of the first OAE's supporting architecture where every component involved in the previously mentioned steps is included together with some technological details and additional elements (e.g. platform and applications) that will be discussed in the following section.

We want to focus more on OAE's unified data, whose conceptual structure has been properly modelled by an ontology [22] which formally represents knowledge about the AEL domain as a set of interrelated concepts consisting of classes, types, properties and relations. An ontology graph is proposed in Figure 2 where classes and relations are described in English.

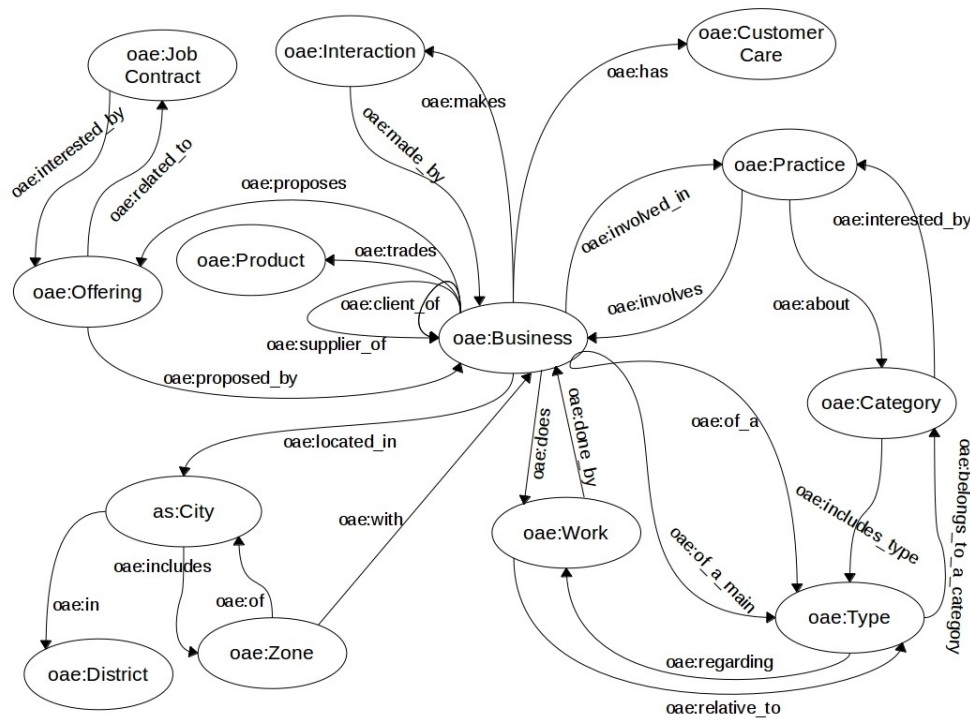

Figure 2: OAE - AEL domain ontology

Being highly declarative and expressive by definition, this ontology represents an accessible form to describe OAE's LOD triples and will help disseminate information on AEL when published online by the end of the project. The ontology has been developed using OWL [23] and is released in different coding formats (e.g. Manchester, Turtle) for the benefit of future users such as ordinary citizens, media people, data scientists, knowledge engineers and software developers interested in the AEL domain.

In the spirit of the Web of Data, links to existing vocabularies (e.g. FOAF, Geo, Dublin Core) have been included wherever possible and applicable in order to share already available information and knowledge. As a result, OAE's LOD triples are published as standard RDF [28] interconnected data (Figure 3) ready to be queried (via a SPARQL [24] endpoint), (re)used, explored, reasoned upon according to the ontology to check its consistency (as we have already tested with an OSS reasoner) and possibly make new discoveries and future inferences.

We deem this interesting and promising in the context of AEL domain. Consistently with knowledge generation and sharing advocated by degrowth movements, we believe that expanding the scope of the Semantic Web of Data to include social and economic innovative domains may progressively serve stakeholders to more deeply explore data of interest and help reach out to common people on the important issue of a future sustainable life.

A screenshot of a web browser window displaying RDF data in standard format. The browser's address bar shows the URL 'http://dati.openaltreconomia.it/oea\_data/oea\_lod.rdf'. The page content is a list of RDF triples, including information about cities, zones, and activities. The triples are formatted as XML-like structures with various namespaces and properties. For example, one triple describes a city with its name, coordinates, and a homepage. Another triple describes a zone with its name and address. The browser's interface, including the menu bar and search bar, is visible at the top.

Figure 3: OAE - LOD in standard RDF format

## OAE's free Open Source Software

OAE's LOD triples can be queried via a SPARQL endpoint by knowledgeable individuals with specific skills in the Semantic Web arena. In order to further allow access to and use of AEL-related open data, we have designed and implemented as free OSS a system platform supporting a number of services that can be used by any application developer and software programmer interested in the domain.

In addition to general user management and profiling, we consider particularly interesting the abstraction layer offered by this platform on top of LOD-based information and knowledge representations (see Figure 1). Computer scientists and technologists not (yet) expert on LOD, ontologies and SPARQL queries are spared the details of something they do not master. However, they can still fully exploit the platform's open API to invoke AEL data requests and receive responses in standard JSON format [25] via REST calls [26] over the Web. Thus, they are free to both develop their own applications and services making use of the platform and enhance the platform's functionalities on top of raw LOD data should they become properly skilful and proficient in the use of underlying LOD-related technologies.

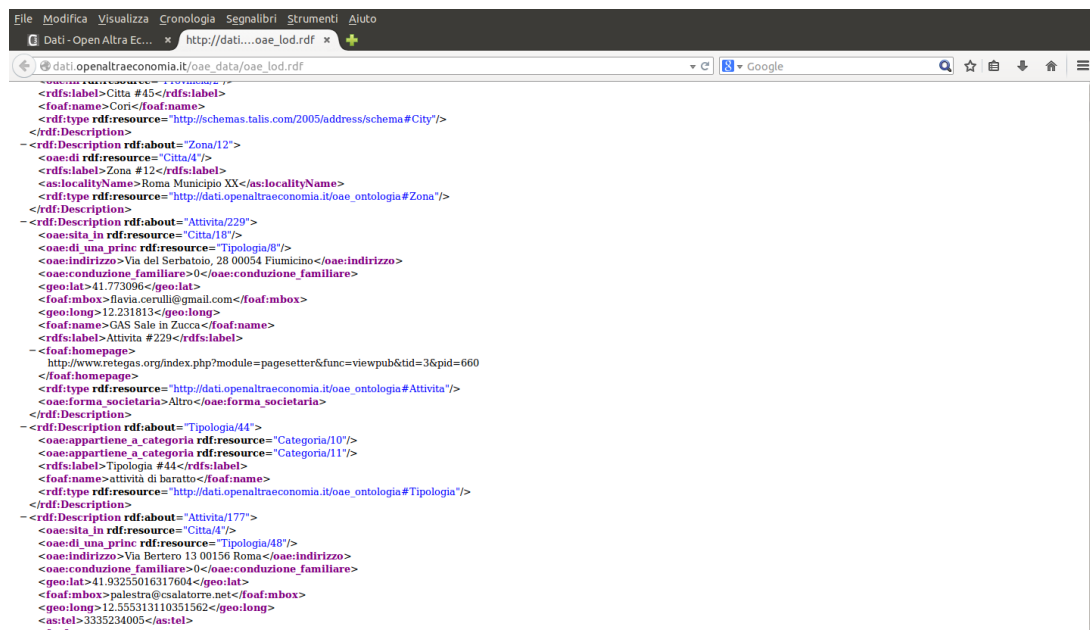
Examples of end-user applications are a further contribution expected in the OAE project and their

release to the general public is just about to be scheduled at the time of this writing. Having published LOD on the socio-economic innovation represented by the AEL consortium is all well and good and the aforementioned abstraction service platform is hopefully useful to further promote a (re)use of that data. Nevertheless, end-user applications are needed to demonstrate how to practically exploit the data both to “spread the word” on AEL's activities/businesses and to possibly make fruitful use of the very LOD format.

Indeed, LOD triples are instances of graph data where edges between two nodes (or vertices) represent specific properties that could be measured (e.g. by assigning specific weights to each edge [27]). Edges could then be visualised according to their weights to emphasise a particular property and study the AEL domain more in depth (e.g. highlighting all AEL activities of a certain AEL type or pointing out all those businesses practising “a lot” a given AEL category).

On the other hand, simpler and more traditional applications can be developed to offer data access and possibly support data collection both on the Web and on the move. To this end we are releasing a Web application (Figure 4) and an Android app (Figure 5) allowing end users to browse OAE's LOD triples by selecting different types of search criteria. For instance, they might decide to look for community-supported agricultures in the area where they live or fair trade shops in their immediate vicinity while on the go. Or they might check for social events or ethical food in a specific public place they already happen to know.

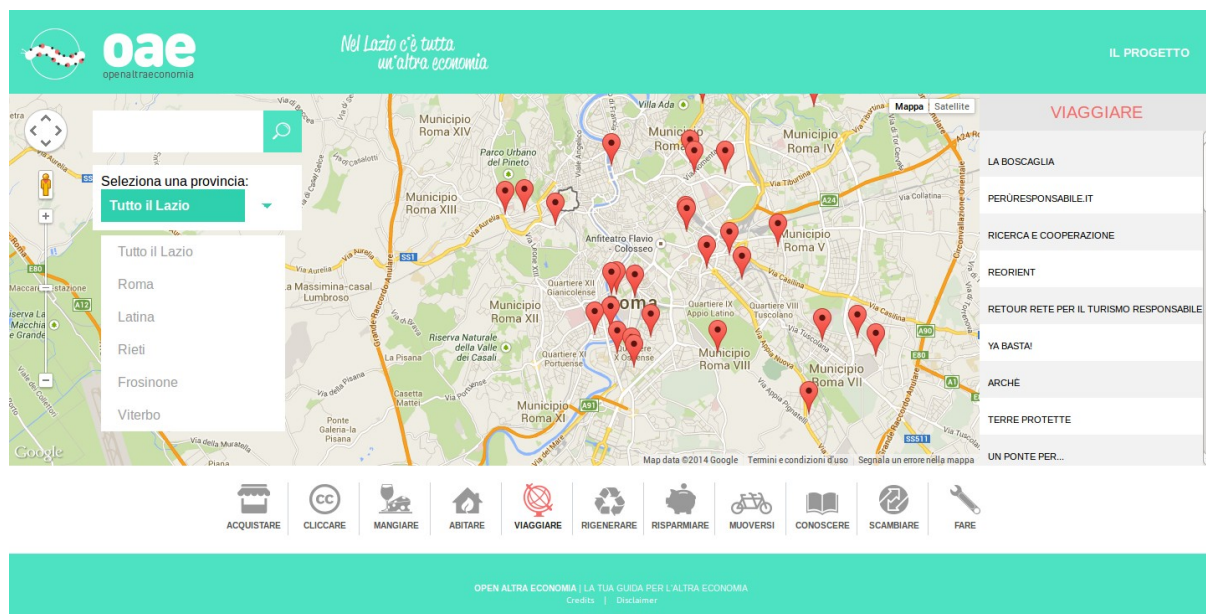

Figure 4: OAE - Web Application

Basically, it is our ambition to let interested users enjoy a sort of AEL up-to-date directory helping them live forms of alternative, sustainable experiences whenever they like to and wherever they happen to be. Additionally, to further encourage people's engagement and participation in the AEL movement, we have envisaged a “crowd-sourcing” mechanism to let users comment and report on existing points of interest as well as signal new ones to be added to the dataset after a proper double check in the back-end.

We plan to release all the applications as free OSS. Indeed, it is our strong belief that keeping data and software free and open when they are meant to support social innovation movements and campaigns is crucial if we want to try and empower people and have them on board to advance such valuable causes. In our case, not only can people benefit from a direct access to information and knowledge sharing on AEL's practices, they might also help improve the quality of data and supporting software as it happens, for instance, in existing and flourishing online communities of software developers. A catchphrase summarising our dreams and goals could be used by

interpreting in English the Italian acronym OAE: Open public data, free Applications and Empower people!

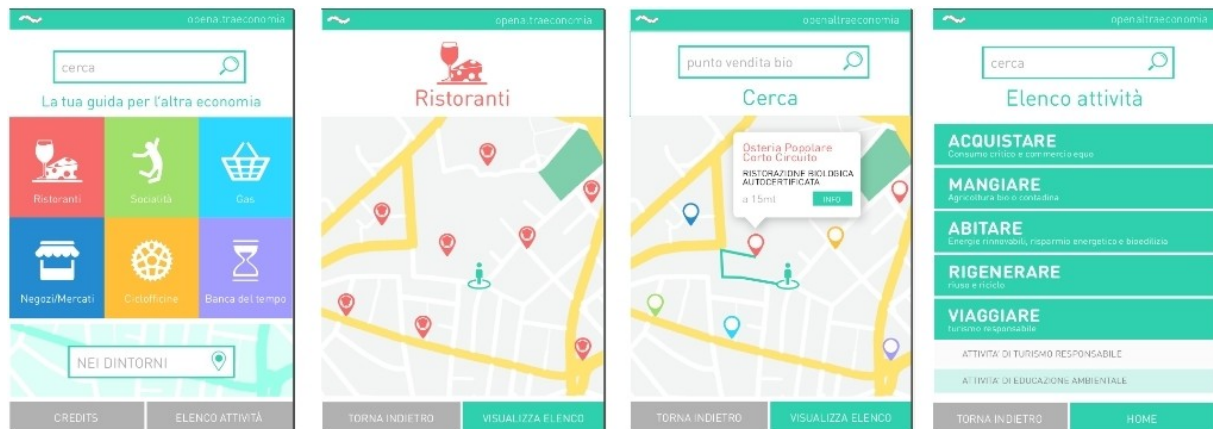

Figure 5. OAE - Android App

## Conclusions and further work

We have presented a technical report on “Open Altra Economia” (OAE) an ongoing 1-year R&D project aimed at using Open Data and free OSS to help make advances in the economic and social innovation represented by the AEL consortium in the Italian Lazio region. We strongly believe that existing and emerging forms of sustainable social, political and economic endeavours should be increasingly sustained and supported by cutting-edge technologies.

Indeed, assisting social innovation schemes with scientific and technological progress should be one of the main pillars of present and future policies for a good democratic and advanced society. In the context of our project, by directing our specific skills and know-how in information and communication technologies towards the publication and dissemination of data, actions and practices regarding fairer businesses and more sustainable consumption patterns, we hope to blaze a trail in attracting computer scientists and technologists to work for a good social cause.

Furthermore, the availability of democratic tools such as data and software applications licensed to be open and free to use (e.g. via CC-BY-SA and GPL licenses) should hopefully motivate citizens to become more involved in AEL's activities and initiatives in the Lazio region. This could also give a significant contribution in strengthening a movement which is surely on the rise, but is also still rather fragmented in the territory.

Specifically, we have so far conceived and implemented a process to collect and control data about AEL's innovative domain and publish it as standard LOD triples. Along with the process, a supporting distributed system architecture has been put in place to accommodate data and applications for the benefit of a variety of different external actors and stakeholders (e.g. ordinary citizens, administrators, planners, scientists and technologists).

To this extent, a relevant role is played by an abstraction service platform, implemented as free OSS, hiding out behind a standard Web-based open API low-level data models and “crunching” mechanisms based on graph data representations, ontologies and SPARQL endpoint. We are currently devoting efforts to finalise end-user application development to be able to release as free OSS initial examples of effective user experience on AEL's LOD data both over the Web and on mobile devices.

Given the OAE project's current experimental nature as well as its time and budget constraints, we anticipate some limitations that will be possibly addressed in future work after the project is

completed. A detailed system test plan should be properly arranged and carried out to evaluate overall system performance and possible technical pitfalls during initial trials. On the other hand, some adjustments and optimization steps towards greater robustness and scalability of the proposed solutions have been already determined should they be needed.

Similarly, great care should be put on data quality and consistency that we can only guarantee until a certain extent at the moment. Both the adoption of automatic data ETL tools and the availability of an application-hosted data “crowd-sourcing” to upload and populate data on the AEL's domain are prone to mistakes, lack of precision, false reported information and knowledge. As a consequence, the double check and validation steps already part of the general process put in place (e.g. manual control via ad-hoc application) should be refined and periodically carried out on datasets to make sure information as fresh and up-to-date as possible is made available to the general public. In general, we consider rather natural taking into account a polishing up measure of every single aspect related to crucial data loading into the unified persistence.

In addition to technical system testing and data quality control, we envisage an adoption of both quantitative and qualitative methods to measure the success of our project over time. If there is no doubt about technical R&D and scientific knowledge-related challenges that we have had to face (an are still facing) in the context of the project (e.g. power and promise of (big) linked open data, ontology-based graph data modelling, novel data representations and querying, supporting distributed information systems), it is the project's expected impacts on the AEL's movement and the people participating in it that really matters.

For this reason, we are considering open source analytics software such as [29] providing valuable insights into specific parameters of interest (e.g. total number and frequency of data queries on the SPARQL endpoint, application accesses and downloads in a given time frame, number of feedback and comments on data and applications) as well as questionnaires to properly evaluate if and how we will be reaching out to people and have them inspired and involved to help us improve data and applications serving the worthwhile cause of the AEL consortium.

## References

- [1] Participatory Economics, [http://en.wikipedia.org/wiki/Participatory\\_economics](http://en.wikipedia.org/wiki/Participatory_economics)
- [2] Jackson, T. Prosperity Without Growth (Economics for a Finite Planet), Earthscan 2009
- [3] Legge Regionale Altra Economia: "Disposizioni per la diffusione dell'Altra Economia nel Lazio", approvata in giunta il 28-11-2008 (legge 20).
- [4] Legge Regionale in materia di dati aperti e riutilizzo di informazioni e dati pubblici: "Disposizioni in materia di dati aperti e riutilizzo di informazioni e dati pubblici e iniziative connesse", legge Regionale n. 7/2012, approvata dal consiglio regionale il 23/05/2012.
- [5] European Commission Decision C (2013) 8631 of 10 December 2013. HORIZON 2020 WORK PROGRAMME 2014–2015 5. Leadership in enabling and industrial technologies i. Information and Communication Technologies ([http://ec.europa.eu/research/participants/data/ref/h2020/wp/2014\\_2015/main/h2020-wp1415-leit-ict\\_en.pdf](http://ec.europa.eu/research/participants/data/ref/h2020/wp/2014_2015/main/h2020-wp1415-leit-ict_en.pdf))
- [6] European Commission Enterprise and Industry. Reviewing community innovation policy in a changing world, 2009.
- [7] Council of Europe. Rethinking consumer behaviour for the well-being of all - Reflections on individual consumer responsibility, 2008.
- [8] Council of Europe. Well-being for all - Concepts and tools for social cohesion, 2008.
- [9] SCF Associates Ltd. A green knowledge society. An ICT policy agenda to 2015 for Europe



future knowledge society, 2009.

- [10] European Commission Directorate-General for Research Socio-economic Sciences and Humanities. The World in 2025. Rising Asia and socio-ecological transition, 2009.
- [11] Open Data, [http://en.wikipedia.org/wiki/Open\\_data](http://en.wikipedia.org/wiki/Open_data)
- [12] Open Source Software, [http://en.wikipedia.org/wiki/Open\\_Source\\_Software](http://en.wikipedia.org/wiki/Open_Source_Software)
- [13] Open Government, [http://en.wikipedia.org/wiki/Open\\_Government](http://en.wikipedia.org/wiki/Open_Government)
- [14] Semantic Web of Data, <http://www.w3.org/standards/semanticweb/data>
- [15] Linked Data, [http://en.wikipedia.org/wiki/Linked\\_data](http://en.wikipedia.org/wiki/Linked_data)
- [16] Berners Lee, T. 5 star Open Data, <http://5stardata.info/>
- [17] DECRETO LEGISLATIVO 7 marzo 2005, n. 82, <http://www.normattiva.it/uri-res/N2Ls?urn:nir:stato:decreto.legislativo:2005-03-07;82!vig=>
- [18] DECRETO LEGISLATIVO 30 dicembre 2010, n. 235, <http://www.normattiva.it/uri-res/N2Ls?urn:nir:stato:decreto.legislativo:2010-12-30;235!vig=>
- [19] W3C, Publishing Open Government Data, <http://www.w3.org/TR/gov-data/>
- [20] Agenzia per l'Italia Digitale, An Overview of the Italian Guidelines for Semantic Interoperability through Linked Open Data, [http://www.agid.gov.it/sites/default/files/documentazione\\_trasparenza/semanticinteroperability\\_od\\_en\\_3.pdf](http://www.agid.gov.it/sites/default/files/documentazione_trasparenza/semanticinteroperability_od_en_3.pdf)
- [21] Extract, Transform, Load (ETL), [http://en.wikipedia.org/wiki/Extract,\\_transform,\\_load](http://en.wikipedia.org/wiki/Extract,_transform,_load)
- [22] Ontology (information science), [http://en.wikipedia.org/wiki/Ontology\\_%28information\\_science%29](http://en.wikipedia.org/wiki/Ontology_%28information_science%29)
- [23] W3C, OWL Web Ontology Language – Overview, <http://www.w3.org/TR/owl-features/>
- [24] W3C, SPARQL 1.1 Overview, <http://www.w3.org/TR/sparql11-overview/>
- [25] JavaScript Object Notation (JSON), <http://json.org/>
- [26] Representational State Transfer (REST), [http://en.wikipedia.org/wiki/Representational\\_state\\_transfer](http://en.wikipedia.org/wiki/Representational_state_transfer)
- [27] Weighted graphs and networks, [http://en.wikipedia.org/wiki/Glossary\\_of\\_graph\\_theory#Weighted\\_graphs\\_and\\_networks](http://en.wikipedia.org/wiki/Glossary_of_graph_theory#Weighted_graphs_and_networks)
- [28] W3C, Resource Description Framework (RDF), <http://www.w3.org/RDF/>
- [29] PIWIK Open Analytics Platform, <http://piwik.org/>